

STAR 8 STAR 10

The Haulotte® advantages

- Full electric drive with the ability to drive at full height
- Proportional controls provide for smooth and progressive movements
- Narrow turning radius for better accessibility
- Increased safety with 3° slope sensor and pot hole protection
- The positive/negative jib offers more flexibility throughout the working envelope
- 2.8 mph (4.5 km/h) travel speed
- 23% gradeability
- Low total weight for easier transport and more applications
- Ergonomic and spacious cage design
- Robust, reliable and easy to maintain

STANDARD FEATURES

- 24 V Electric motor
- 24 V - 240 Ah traction batteries
- 30 Amp battery charger
- Battery charge indicator
- 2 drive speed
- 2 back driving wheels
- 2 front steering wheels
- Non marking tyres
- Free wheel device
- Hourmeter
- Horn in cage
- Emergency stop buttons at cage and ground
- 2 Control stations, cage and ground

OPTIONS & ACCESSORIES

- Centralised battery filling
- Flashing beacon
- Safety harness anchor points
- Motion alarm
- 220V line to cage
- Airline to cage

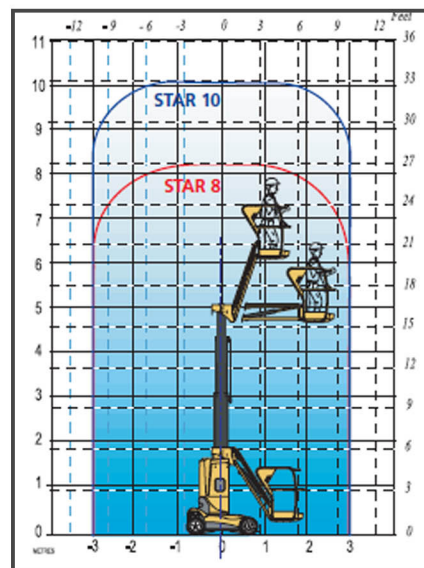
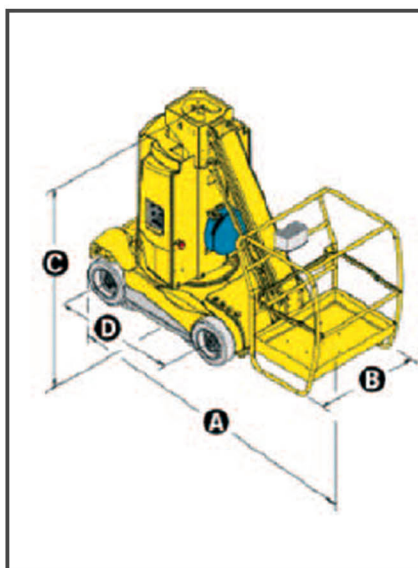

SPECIFICATIONS

	Star 8	Star 10
Working Height	8.20 m / 28 ft 9 in	10 m / 32 ft 10 in
Platform Height	6.20 m / 22 ft 2 in	8 m / 26 ft 3 in
Horizontal outreach	3,1m / 10 ft 2 in	
Platform Capacity	200 kg / 441 lb	
A. Length	2,65m / 8 ft 8 in	
B. Width	0.99m / 3ft 2in	
C. Stowed Height	1.99 m / 6 ft 6 in	
D. Wheelbase	1.2 m / 3 ft 11 in	
E. Ground Clearance	de 2,5 cm à 10 cm / 1 in to 4 in	
Platform size	0.92x0.68m / 36 in x 27 in	
Tailswing	0	
Drive speed	0.7 - 4.5 km/h / 0.43 - 2.8 mph	
Outside turning radius	1.87m / 6ft 1 in	
Turntable rotation	345°	
Traction batteries	24 V (2 x 12 V) / 240 Ah	
Gradeability	23%	
Tilt alarm	3°	
Non marking tyres	16" x 5" x 10,5"	
Weight	2700kg / 5952 lb	2760 kg / 6085 lb

STAR 8 STAR 10



- 10 ft 2 in (3,1m) outreach.
- Compact: 345°. Rotation with zero tail swing.
- 441 lb (200 kg) platform capacity.
- Proportional electric controls.
- High autonomy.
- Internal and external use