



SJ6826/32 RT

ROUGH TERRAIN SCISSORS

STANDARD FEATURES

- ✔ Crossover symmetrical 4WD
- ✔ Drivable at full height with roll out deck fully extended
- ✔ Independent/auto leveling outriggers
- ✔ 1.52 m roll out extension deck
- ✔ Diesel engine
- ✔ 90° swing out engine tray
- ✔ Multiple wet disc SAHR brakes
- ✔ Wiring for AC outlet on platform
- ✔ Up to 50% gradeability (SJ6826 RT)
- ✔ Tilt alarm with drive & lift cut-out
- ✔ All motion audible alarm
- ✔ Overload sensing system
- ✔ Lowering warning system
- ✔ Lanyard attachment points
- ✔ Operator horn
- ✔ Flashing lights
- ✔ Hinged railing system
- ✔ Forklift pockets and tie down/lift lugs
- ✔ Full height spring hinged gate at rear of unit
- ✔ Relay based control system
- ✔ Colour coded and numbered wiring system
- ✔ Foam-filled non-marking tyres

ACCESSORIES AND OPTIONS

- ✔ RT heavy duty pipe rack
- ✔ Tool caddy
- ✔ Diesel scrubber



SJ6826/32 RT ROUGH TERRAIN SCISSORS

DIMENSIONS	SJ6826 RT	SJ6832 RT
Work Height	9.92 m	9.92 m
Raised Platform Height	7.92 m	7.92 m
Lowered Platform Height	1.23 m	1.23 m
Overall Width	1.76 m	1.76 m
Overall Length	3.35 m	3.35 m
Stowed Height (Rails Up)	2.37 m	2.37 m
Stowed Height (Rails Down)	1.61 m	1.61 m
Platform Width (Inside Dimension)	1.42 m	1.42 m
Platform Length (Inside Dimension)	2.44 m	2.44 m

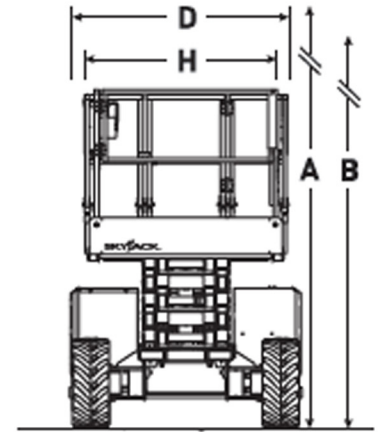

SPECIFICATIONS	SJ6826 RT	SJ6832 RT
Extension Deck	1.52 m	9.92 m
Ground Clearance	0.20 m	7.92 m
Wheelbase	2.04 m	1.23 m
Weight	3,305 kg	1.76 m
Gradeability	50%	3.35 m
Turning Radius (Inside)	1.52 m	2.37 m
Turning Radius (Outside)	3.96 m	1.61 m
Lift Time (With Rated Load)	36 sec	1.42 m
Drive Speed (Stowed)	6.1 km/h	2.44 m
Drive Speed (Raised)	0.6 km/h	
Maximum Drive Height	Full Height	
Capacity (Overall)	567 kg	
Maximum # of Persons (0 wind rating)	4	
Maximum # of Persons (12.5 m/sec wind rating)	4	

